

Operator's manual

Gasoline cut-off saw

BTS

635s

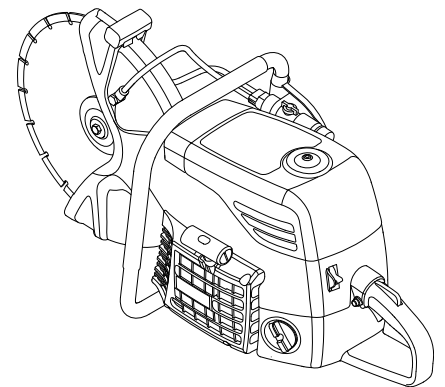

Model	BTS635s
Document	5100011077
Issue	07.2017
Version	03
Language	en

Copyright © 2017 Wacker Neuson Produktion GmbH & Co. KG

Printed in Germany

All rights are reserved, in particular the worldwide applicable copyright, right of duplication and right of distribution.

This document may only be used by the recipient for the intended purpose. The document may not be reproduced entirely or partially, or translated into any other language.

Reproduction or translation, even extracts thereof, only with written approval of Wacker Neuson Produktion GmbH & Co. KG.

Any breach of the statutory provisions, in particular the protection of copyright, will lead to civil and criminal prosecution.

Wacker Neuson Produktion GmbH & Co. KG is constantly working on the improvement of its products as part of the technical further development. Therefore, we reserve the right to make changes to the illustrations and descriptions in this documentation without incurring any obligation to make changes to machines already delivered.

Errors excepted.

The machine on the cover may have special equipment (options).



Manufacturer

Wacker Neuson Produktion GmbH & Co. KG

Wackerstraße 6

D-85084 Reichertshofen

www.wackerneuson.com

Tel.: +49 845 3340 3200

E-mail address: service-LE@wackerneuson.com

Original operator's manual

1	Foreword	5
2	Introduction	6
2.1	Means of representation for this operator's manual	6
2.2	Wacker Neuson representative	7
2.3	Described machine types	7
2.4	Identification of the machine	8
3	Safety	9
3.1	Principle	9
3.2	Qualification of the operating personnel	12
3.3	Protective gear	13
3.4	Transport	14
3.5	Operating safety	15
3.6	Safety during the operation of hand machines	17
3.7	Safety during the operation of combustion engines	17
3.8	Safety during cut-off saw operation	20
3.9	Maintenance	24
3.10	Safety devices	25
4	Safety and information labels	26
4.1	Safety and information icons	29
5	Scope of delivery	30
6	Structure and function	31
6.1	Application	31
6.2	Functionality	31
7	Components and operator's controls	32
8	Transport	35
9	Initial start up	36
9.1	Mounting the cutting attachment on the outside	36
10	Use and operation	41
10.1	Prior to starting the machine	41
10.1.1	Checks before startup	41
10.1.2	Changing the cutting blade	41
10.2	Starting up	43
10.2.1	Starting the engine	43
10.3	Operating the machine	47
10.4	Decommissioning	48

11	Maintenance	49
11.1	Maintaining the emission control system	49
11.2	Maintenance schedule	50
11.3	Maintenance work	51
11.3.1	Cleaning the machine	51
11.3.2	Topping up with fuel	53
11.3.3	Tightening the V-belt	54
11.3.4	Checking the thrust washers	54
11.3.5	Cleaning/Changing the air cleaner	55
11.3.6	Checking/cleaning/replacing the spark plug	57
11.3.7	Replacing the V-belt	59
11.3.8	Replacing the fuel filter	62
11.3.9	Setting the idle speed	63
11.3.10	Cleaning the spark arrestor	64
11.3.11	Cleaning the exhaust port	65
12	Troubleshooting	67
13	Accessories	68
14	Storage	69
15	Technical data	70
15.1	BTS 635s	70
15.2	Fuel mixture table	72
16	Emission Control Systems Information and Warranty	73
16.1	Emission Control System Background Information	73
16.2	Limited Defect Warranty for Wacker Neuson Emission Control Systems	74
	EC Declaration of Conformity	79

1 Preface

This operator's manual contains important information and procedures for the safe, proper and economic operation of this Wacker Neuson machine. Carefully reading, understanding and observing is an aid to avoiding hazards, repair costs and downtime, and therefore to increasing the availability and service life of the machine.

This operator's manual is not a manual for extensive maintenance or repair work. Such work should be carried out by Wacker Neuson service or by technically trained personnel. The Wacker Neuson machine should be operated and maintained in accordance with this operator's manual. An improper operation or improper maintenance can pose dangers. Therefore, the operator's manual should be constantly available at the location of the machine.

Defective machine parts must be exchanged immediately!

If you have any questions concerning the operation or maintenance, a Wacker Neuson contact person is always available.

2 Introduction

2.1 Means of representation for this operator's manual

Warning symbols

This operator's manual contains safety information of the categories: DANGER, WARNING, CAUTION, NOTICE.

They should be followed to prevent danger to life and limb of the operator or damage to equipment and exclude improper service.



DANGER

This warning notice indicates immediate hazards that result in serious injury or even death.

- ▶ Danger can be avoided by the following the actions mentioned.
-



WARNING

This warning notice indicates possible hazards that can result in serious injury or even death.

- ▶ Danger can be avoided by the following the actions mentioned.
-



CAUTION

This warning notice indicates possible hazards that can result in minor injury.

- ▶ Danger can be avoided by the following the actions mentioned.
-

NOTICE

This warning notice indicates possible hazards that can result in material damage.

- ▶ Danger can be avoided by the following the actions mentioned.
-

Notes

Note: Complementary information will be displayed here.

Instructions

- ▶ This symbol indicates there is something for you to do.
- 1. Numbered instructions indicate that you have to carry out something in a defined sequence.
- This symbol is used for lists.

2.2 Wacker Neuson representative

Depending on your country, your Wacker Neuson representative is your Wacker Neuson service, your Wacker Neuson affiliate or your Wacker Neuson dealer.

You can find the addresses in the Internet at www.wackerneuson.com.

The address of the manufacturer is located at the beginning of this operator's manual.

2.3 Described machine types

This operator's manual is valid for different machine types from a product range. Therefore some figures can differ from the actual appearance of your machine. It is also possible that the descriptions include components which are not a part of your machine.

Details for the described machine types can be found in the chapter *Technical data*.

2.4 Identification of the machine

Nameplate data

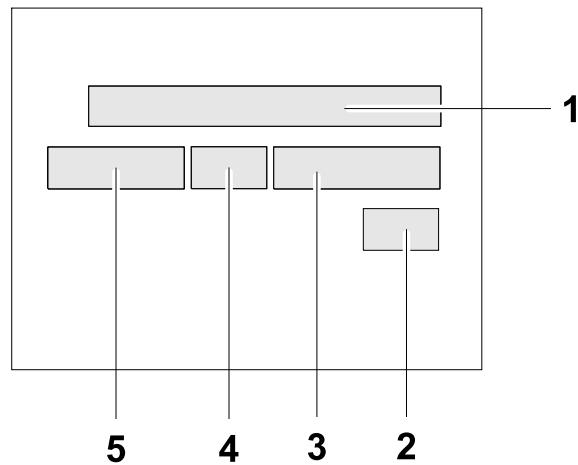

The nameplate lists information that uniquely identifies your machine. This information is needed to order spare parts and when requesting additional technical information.

► Enter the information of your machine into the following table:

Item	Designation	Your information
1	Group and type	
2	Construction year	
3	Machine no.	
4	Version no.	
5	Item no.	

3 Safety

3.1 Principle

State of the art

This machine has been constructed with state-of-the-art technology according to the recognized rules of safety. Nevertheless, when used improperly, dangers to the life and limb of the operator or to third persons or damage to the machine or other materials cannot be excluded.

Proper use

The machine must only be used for the following purposes:

- Cutting concrete, stone and ceramic.
- Cutting metal.
- Cutting asphalt.

The machine may only be used with cutting blades that are intended for use with the machine and the material to be cut.

The machine may not be used for the following purposes:

- Cutting wood.
- Cutting plastics.
- Cutting materials that contain asbestos or other hazardous materials.
- Cutting fibrous or soft materials.
- Grinding (with the side surface of the cutting blade).

The machine may not be operated with blades, knives, brushes, etc.

Do not use the machine as a hand-held circular saw.

Its proper use also includes the observance of all instructions contained in this operator's manual as well as complying with the required service and maintenance instructions.

Any other use is regarded as improper. Any damage resulting from improper use will void the warranty and the liability on behalf of the manufacturer. The operator assumes full responsibility.

Structural modifications

Never attempt to modify the machine without the written permission of the manufacturer. To do so will endanger your safety and the safety of other people! In addition, this will void the warranty and the liability on behalf of the manufacturer.

Especially the following are cases of structural modifications:

- Opening the machine and the permanent removal of components from Wacker Neuson.
- Installing new components which are not from Wacker Neuson and not equivalent to the original parts in design and quality.
- Installation of accessories which are not from Wacker Neuson.

It is no problem to install spare parts from Wacker Neuson.

It is no problem to install accessories that are available in the Wacker Neuson product range of your machine. Please refer to the installation regulations in this operator's manual.

Do not drill into the housing, e. g. to install signs. Water could penetrate the housing and damage the machine.

Requirements for operation

The ability to operate the machine safely requires:

- Proper transport, storage and setup.
- Careful operation.
- Careful service and maintenance.

Operation

Operate the machine only as intended and only when in proper working condition.

Operate the machine in a safety-conscious manner with all safety devices attached and enabled. Do not modify or disable any safety devices.

Before starting operation, check that all control and safety devices are functioning properly.

Never operate the machine in a potentially explosive environment.

Maintenance

Regular maintenance work is required in order for the machine to operate properly and reliably over time. Failure to perform adequate maintenance reduces the safety of the machine.

- Strictly observe the prescribed maintenance intervals.
- Do not use the machine if it requires maintenance or repairs.

Malfunctions

If you detect a malfunction, you must shut down and secure the machine immediately.

Eliminate the malfunctions that impair safety immediately!

Have damaged or defective components replaced immediately!

For further information, refer to chapter *Troubleshooting*.

Spare parts, accessories

Use only spare parts from Wacker Neuson or such that are equivalent to the original parts in design and quality.

Only use accessories from Wacker Neuson.

Non-compliance will exempt the manufacturer from all liability.

Exclusion of liability

Wacker Neuson will refuse to accept liability for injuries to persons or for damage to materials in the following cases:

- Structural modifications.
- Improper use.
- Failure to comply with this operator's manual.
- Improper handling.
- Using of spare parts which are not from Wacker Neuson and not equivalent to the original parts in design and quality.
- Using of accessories which are not from Wacker Neuson.

Operator's manual

Always keep the operator's manual near the machine or near the worksite for quick reference.

If you have misplaced the operator's manual or require an additional copy, contact your Wacker Neuson representative or download the operator's manual from the Internet (www.wackerneuson.com).

Always hand over this operator's manual to other operators or to the future owner of the machine.

Country-specific regulations

Observe the country-specific regulations, standards and guidelines in reference to accident prevention and environmental safety, for example those pertaining to hazardous materials and wearing protective gear.

Complement the operator's manual with additional instructions taking into account the operational, regulatory, national or generally applicable safety guidelines.

Operator's controls

Always keep the operator's controls of the machine dry, clean and free of oil or grease.

Operating elements such as ON/OFF switch, throttle levers etc. may not be locked, manipulated or changed without authorization.

Checking for signs of damage

Inspect the machine when it is switched off for any signs of damage at least once per work shift.

Do not operate the machine if there is visible damage or defects.

Have any damage or defects eliminated immediately.

Supervision

Never leave the machine running unattended!

3.2 Qualification of the operating personnel

Operator qualifications

Only trained personnel are permitted to start and operate the machine. The following rules also apply:

- You are at least 18 years of age.
- You are physically and mentally fit.
- You have received instruction on how to independently operate the machine.
- You have received instruction in the proper use of the machine.
- You are familiar with required safety devices.
- You are authorized to start machines and systems in accordance with the standards governing safety.
- Your company or the operator has assigned you to work independently with this machine.
- Do not operate the machine if you have a pacemaker.

Incorrect operation

Incorrect operation or misuse by untrained personnel can endanger the health and safety of the operator or third persons and also cause machine and material damage.

Operating company responsibilities

The operating company must make the operator's manual available to the operator and ensure that the operator has read and understood it.

Work recommendations

Please observe the recommendations below:

- Work only if you are in a good physical condition.
- Work attentively, particularly as you finish.
- Do not operate the machine when you are tired.
- Carry out all work calmly, circumspectly and carefully.
- Never operate the machine under the influence of alcohol, drugs or medication. This can impair your vision, reactions and your judgment.
- Work in a manner that does not endanger others.
- Ensure that no persons or animals are within the danger zone.

3.3 Protective gear

Work clothing

Clothing should be appropriate, i.e. should be close-fitting but not restrict your movement.

When on construction sites, do not wear long hair loosely, loose clothing or jewelry including rings. These objects can easily get caught or be drawn in by moving machine parts.

Only wear clothing made of material that is not easily flammable.

Personal protective gear

Wear personal protective gear to avoid injuries or health hazards:

- Non-skid, hard-toed shoes.
- Work gloves made of durable material.
- Overalls made of durable material.
- Hard hat.
- Ear protection.
- Face protection.
- Eye protection.
- Breathing protection in the case of dusty ambient air.

When cutting metal wear work clothing made of material that is not easily flammable. Danger of fire due to sparks.

Ear protection

This machine generates noise that exceeds the country-specific permissible noise levels (individual rating level). It may therefore be necessary to wear ear protection. You can find the exact value in the chapter *Technical Data*.

When wearing ear protection while working, you must pay attention and exercise caution because your hearing is limited, e.g. in case someone screams or a signal tone sounds.

Wacker Neuson recommends that you always wear ear protection.

Wear special ear protection which allows you to hear audio signals.

Breathing protection

If a lot of dust is produced when cutting, always wear suitable breathing protection.

Use the water supply or an extractor if possible.

Provision of fire extinguishers

Ensure that a fire extinguisher is always to hand on the worksite.

Do not exceed the service life

The machine produces vibrations and generates noise.

Observe the regulations which apply in your country and guidelines concerning the maximum service life of the machine.

Always wear the prescribed safety clothing.

Details on noise and vibration levels produced by the machine can be found in chapter *Technical Data*.

3.4 Transport

Carrying the machine

Do not carry or transport the machine when the cutting blade is rotating.

Only carry the machine if the engine is idling and the cutting blade is not rotating.

Switching off the machine

Before you transport the machine, it must be switched off, and the engine must be given sufficient time to cool down.

Emptying the tank

Wacker Neuson recommends that the fuel tank be emptied and the carburetor run dry prior to transporting it. Fuel could run out, e.g. if the machine is tilted.

Observe the national safety guidelines and the hazardous materials regulations that apply to the respective means of transportation.

Transporting the machine

Secure the machine on the transport device against tilting, falling or slipping.

Restarting

Machines, machine parts, accessories or tools that were detached for transport purposes must be re-mounted and fastened before restarting.

Only operate in accordance with the operating instructions.

3.5 Operating safety

Explosible environment

Never operate the machine in a potentially explosive environment.

Work environment

Familiarize yourself with your work environment before you start work. This includes e.g. the following items:

- Obstacles in the work and traffic area.
- Load-bearing capacity of the ground.
- The measures needed to cordon off the construction site from public traffic in particular.
- The measures needed to secure walls and ceilings.
- Options available in the event of an accident.

Safety in the work area

When working with the machine especially pay attention to the following points:

- Electric lines or pipes in work area.
- Gas lines or water lines in the work area.
- Material becoming separated, dropping down or ejected. Make sure that you do not put other persons in danger.
- Pay maximum attention in the vicinity of drops or slopes. Risk of falling.
- Maintain a sufficient distance from flammable materials.

Checks before starting work

Check the following points before beginning work:

- Condition of cutting blade.
- Safety devices.

Starting the machine

Observe the safety information and warning notices located on the machine and in the operator's manual.

Never attempt to start a machine that requires maintenance or repairs.

Start the machine as described in the operator's manual.

Vertical stability

Always make sure that you stand firmly when working with the machine.

- Do not work with the machine on ladders or scaffolding.
- Do not use the machine at heights above shoulder height.

Danger of falling over

Operate the machine so that it cannot tip over or fall down from bordered areas, edges and steps.

Caution with movable parts

Keep your hands, feet and loose clothing away from moving or rotating machine parts. Parts of your body being pulled in or crushed can cause serious injuries.

Caution with toxic materials

Some materials may contain toxic chemicals which are released during demolition. Therefore personal protective equipment must be worn to prevent inhalation of and skin contact with work dust.

No persons endangered

Be sure that no persons are endangered by flying or falling materials. Always work very attentively, and anticipate potential hazards.

Switching off the machine

Switch off the engine in the following situations:

- Before breaks.
- If you are not using the machine.

Before storing the machine, wait until it has completely stopped running.

Store the machine or put it down in such a way that it cannot tilt, fall down or slip.

Storage

Set the machine down or store it securely so that it cannot tilt, fall down or slip.

Storage location

After operation, allow the machine to cool and then store it in a sealed-off, clean and dry location protected against frost and inaccessible to children.

Vibrations

When manually operated machines are intensively used, long-term damage caused by vibrations cannot be precluded.

Observe the relevant legal instructions and guidelines to minimize vibration stress.

Details on vibration stress associated with the machine can be found in the chapter *Technical Data*.

Health hazards due to dust particles or vapor

Working with the machine may cause the release of dust particles or vapor containing hazardous materials, e.g. silicon dust.

Only cut materials which you are familiar with and always wear suitable breathing protection.

3.6 Safety during the operation of hand machines

Safe working with hand machines

Secure loose workpieces with suitable methods.

While working, as a rule hold the machine on the provided handles with both hands.

While working, hold the machine in such a way that hand injuries are avoided when hitting hard objects.

Setting the hand machine down properly

Set the machine down carefully. Do not drop the machine to the floor or from greater heights. Dropping the machine can cause injuries to other persons or the machine itself can be damaged.

3.7 Safety during the operation of combustion engines

Checking for signs of damage

Check the engine while switched off for leaks and cracks in the fuel line, tank and fuel cap at least once per work shift.

Do not operate the machine if there is visible damage or defects.

Have any damage or defects eliminated immediately.

Dangers during operation

Combustion engines can be dangerous, particularly during operation and when refueling.

Read and follow all safety instructions. Otherwise there is a risk of personal injury and/or damage to property!

Do not start the engine near spilt fuel or if you smell fuel – this may cause an explosion!

- Remove the machine from such areas.
- Remove the spilt fuel immediately!

Do not change the engine speed

Do not change the preset engine speed, as this may cause engine damage.

You may only change the idle speed. The idle speed must be set such that the cutting blade does not rotate while the engine is idling.

Preventing fires

Open flames and smoking are strictly prohibited in the immediate vicinity of the machine.

Make sure that waste, such as paper, dry leaves or grass do not accumulate around the exhaust muffler. The waste materials may ignite.

Safety precautions when refueling

Please observe the following safety-relevant instructions when refueling:

- Do not refuel near open flames.
- Do not smoke.
- Turn off the engine before refueling and allow it to cool down.
- Refuel in a well-ventilated environment.
- Wear fuel-proof protective gloves and, if there is the possibility of spraying, protective goggles and clothing.
- Do not inhale fuel vapors.
- Avoid skin and eye contact with fuel.
- For refueling, use clean tools such as a hopper.
- Do not spill fuel, especially onto hot parts.
- Remove any spilt fuel immediately.
- Use the correct fuel grade.
- Do not mix fuel with other liquids.
- Fill the tank only up to the maximum marking. If there is no Maximum marking, do not fill up the tank completely.
- Lock the fuel cap securely after refueling.

Operation in closed rooms

In closed or partially closed rooms such as tunnels, drifts or deep trenches, ensure sufficient ventilation by, for example, providing a powerful exhaust air fan.

Danger of poisoning! Do not inhale exhaust fumes. They contain toxic carbon monoxide that can lead to unconsciousness or death.

Caution with hot parts

Do not touch any hot parts such as the engine block or exhaust muffler during operation or directly afterwards. These parts can become very hot and cause severe burns.

Cleaning the engine

Clean the engine when it is cool to remove any dirt.

Do not use gasoline or solvents. Danger of explosion!

Health hazard due to exhaust fumes

Warning

The engine's exhaust fumes contain chemicals which are known to the State of California to cause cancer, congenital defects or other reproductive anomalies.

Notes on the EPA engine (for USA and Canada)

Caution

This machine is equipped with an EPA certified engine. Operating the machine at an atmospheric pressure below 96 kPa may increase emissions and decrease fuel efficiency and performance.

Do not use any starter sprays

Highly flammable starter sprays pose a fire hazard.

Do not use any starter sprays.

Starter sprays are highly flammable and can cause backfiring and engine damage.

3.8 Safety during cut-off saw operation

Kickback

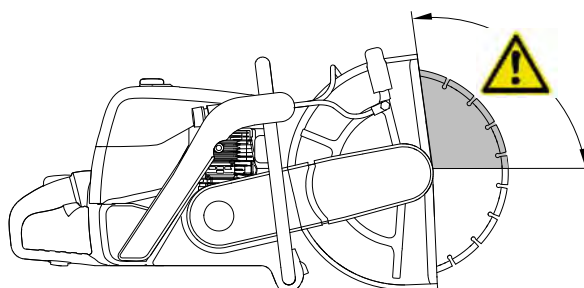

If the upper quarter of the cutting blade is applied to a material, the machine can be flung back toward the operator with great force.

The machine and the rotating cutting blade can cause severe injury.

To prevent kickback, follow these rules:

- While working, as a rule hold the machine on the provided handles with both hands.
- Do not use the upper quarter of the cutting blade to cut.
- Make sure that the material does not shift out of place.
- Ensure that the cut does not become constricted during the cutting process.
- Ensure that the cutting blade does not become pinched during the cutting process.

Pulling away

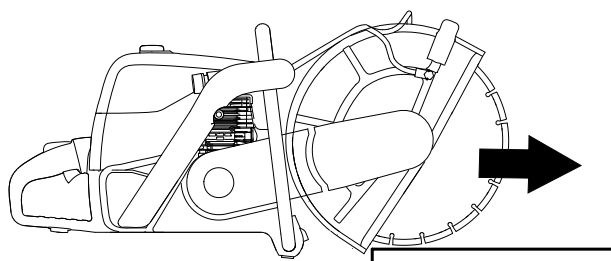

When the cutting blade is set onto the material from above, the machine pulls away toward the front.

While working, as a rule hold the machine on the provided handles with both hands.

Preventing pinching

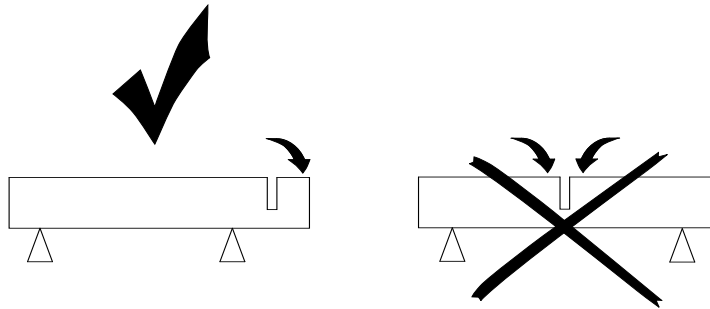

Prevent the cut from becoming constricted and pinching the cutting blade during the cutting process.

Support the material such that the cut remains open and does not become constricted during the entire cutting process.

Notes regarding cutting blades

- The cutting blade must be suitable for use with the cut-off saw.
- The cutting blade must be suitable for the material to be cut.
- The speed allowed for the cutting blade must be the same as or higher than the maximum machine spindle speed.
- Mount the cutting blade such that its rotation direction is the same as that of the machine.
- Only use cutting blades with permissible cutting blade diameters.
- When using cutting blades with a hole diameter greater than the machine shaft, use the suitable adapter ring.
- Only use undamaged cutting blades.
- Ensure that you also follow the instructions of the cutting blade manufacturer.
- Do not use cutting blades that have fallen.
- Change the cutting blade only when the engine has been turned off.
- Always tighten the cutting blade with the specified torque.
- Test the new cutting blade for approx. 1 min at maximum speed (without cutting).
- Do not use the side surface of the cutting blade for grinding.
- Only use cutting blades with use-by dates that have not expired.
- When storing cutting blades, always lay them flat in an area that is protected from frost.

Only operate the machine with a mounted cutting blade

If you operate the machine without a cutting blade, conical spring washer and screw could become loose, causing severe injury.

Only operate the machine with mounted cutting blade.

Belt guard

Never operate the machine without a belt guard!

Exposed V-belts and belt pulleys are dangerous and can cause serious injuries if they pull in any part of your body or if parts are ejected.

Protective hood

Never operate the machine without a protective hood.

The protective hood performs the following functions:

- Protects the operator from the rotating cutting blade.
- Diverts workpiece particles and sparks or chips from a damaged cutting blade away from the operator.

Set the protective hood such that its lower section is almost in contact with the workpiece.

Wet cutting

Use a water sprayer when dust formation is excessive, e.g. when cutting concrete or stone.

Only use cutting blades that are suitable for wet cutting.

Before ending the wet cutting process, allow the cutting blade to run without the water sprayer until it is dry.

Notes regarding work methods

- Set the protective hood such that its lower section is almost in contact with the workpiece. The protective hood can catch material flung away from the work area and divert it away from the operator.
- Always operate the machine at full throttle even when first placing it into the cut.
- When first placing the the cutting blade into the cut, set it slowly onto the material. Excessive pressure can damage the cutting blade.
- Do not press down on the machine while cutting.
- Move the machine in a straight line together with the cutting blade. Pressure from the side can damage the cutting blade.
- Do not use the upper quarter of the cutting blade to cut. Machine kickback can cause severe injury.

Hold the machine with both hands

While working, as a rule hold the machine on the provided handles with both hands.

Do not stand in the machine's swing area

Hold and guide the machine such that no body parts are in the machine's swing area.

Securing the material

Before cutting, secure the material so that it does not slide away or tip over. Do not ever secure the material with your foot.

Remove foreign objects before cutting

Before cutting, remove foreign objects such as nails, etc. from the cutting area.

Supporting the machine's weight

At the end of the cutting procedure the cutting blade no longer supports the machine's weight. The operator must support the machine's weight.

While working, as a rule hold the machine on the provided handles with both hands.

Cutting several materials at once

Do not cut several materials in one cutting procedure.

Cutting very thin materials

Make sure that very thin materials do not get trapped between the cutting blade and the lateral protection cover.

Do not touch a rotating cutting blade

Never touch a rotating cutting blade with your hand or any other body part. Danger of severe injury.

Running cutting blade

The cutting blade continues to run for awhile after the throttle lever is released. Danger of injury.

Danger of fire due to sparks

Danger of fire due to hot workpiece particles flung away from the work area.

- Do not work near flammable materials.
- Only wear clothing made of material that is not easily flammable.

Do not leave any tools inserted

Before operating the machine, make sure that tools have been removed.

3.9 Maintenance

Maintenance work

Service and maintenance work must only be carried out to the extent described in these operating instructions. All other procedures must be performed by your Wacker Neuson representative.

For further information, refer to chapter *Maintenance*.

Switching off the engine

Before carrying out care or maintenance work, switch off the engine and allow it to cool down.

For gasoline powered engines, you must pull off the spark plug cap.

Cleaning

Always keep the machine clean and be sure to clean it each time you have finished using it.

Do not use gasoline or solvents. Danger of explosion!

Do not use high pressure washers. Permeating water can damage the machine. When electrical equipment is present, this can pose a serious injury risk from electric shocks.

Assembling safety devices

If it was necessary to dismantle safety devices, they must be reassembled and checked immediately after completing maintenance work.

Always tighten loosened screw connections, complying with prescribed starting torque.

Handling operating fluids safely

Observe the following points when handling operating fluids, e.g. fuels, oils, greases, coolants etc.:

- Always wear personal safety clothing.
- Avoid skin and eye contact with operating fluids.
- Do not inhale or swallow operating fluids.
- In particular, avoid contact with hot operating fluids. Burn and scalding hazard.
- Dispose of replaced or spilled operating fluids according to the applicable regulations for environmental protection.
- If operating fluids escape from the machine, cease operation of the machine and have it repaired immediately by your Wacker Neuson representative.

3.10 Safety devices



WARNING

Danger of injury due to open moving parts.

- ▶ Only operate the machine with properly installed and functioning safety devices.
 - ▶ Do not modify or remove safety devices.
-

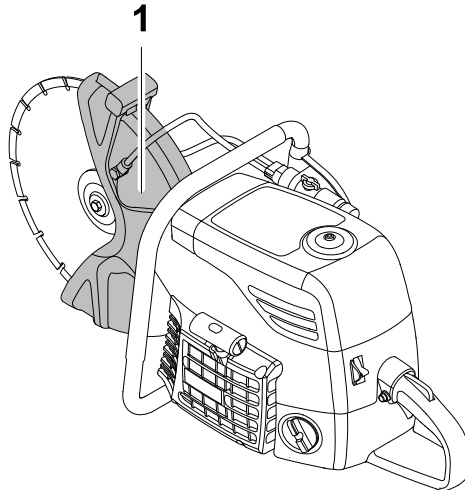

Item	Designation
1	Protective hood

Protective hood

Never operate the machine without a protective hood.

The protective hood performs the following functions:

- Protects the operator from the rotating cutting blade.
- Diverts workpiece particles and sparks or chips from a damaged cutting blade away from the operator.

Set the protective hood such that its lower section is almost in contact with the workpiece.

4 Safety and information labels

Your machine has adhesive labels containing the most important instructions and safety information.





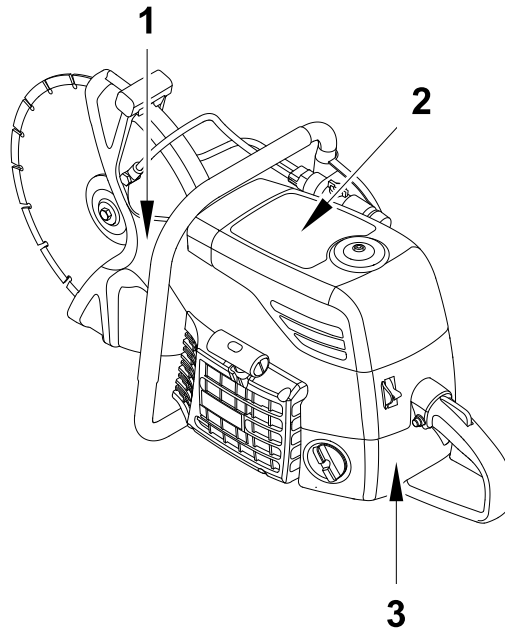

- Make sure that all the labels are kept legible.
- Replace any missing or illegible labels.



The item numbers for the labels are in the parts book.



Item	Label	Description
1		<ul style="list-style-type: none"> ■ Do not exceed the maximum cutting blade diameter. ■ Only use cutting blades with the specified hole diameter. ■ Do not exceed the maximum cutting blade width.
2		<p>The machine may not be operated with blades, knives, brushes, etc.</p>

4 Safety and information labels

Item	Label	Description
2		<p>Wear personal protective gear to avoid injuries or health hazards:</p> <ul style="list-style-type: none"> ■ Hard hat. ■ Ear protection. ■ Eye protection. ■ Breathing protection. ■ Face protection. ■ Work gloves made of durable material. ■ Overalls made of durable material. ■ Non-skid, hard-toed shoes.
2		<p>Danger of fire due to sparks.</p> <ul style="list-style-type: none"> ■ Do not work near flammable materials. ■ Only wear clothing made of material that is not easily flammable.
2		<p>Before operation, read and follow the information in the operator's manual.</p>
2		<p>Smoking and open flames are prohibited. Danger of fire.</p>
2		<ul style="list-style-type: none"> ■ Maximum spindle speed. ■ Maximum peripheral speed. <p>The speed allowed for the cutting blade must be the same as or higher than the maximum machine spindle speed.</p>
2		<p>The machine may only be operated with a fuel mixture consisting of unleaded gasoline and two-cycle engine oil. The mixture ratio is 50:1.</p>
2		<p>Danger of kickback. Machine kickback can cause severe injury. Do not use the upper quarter of the cutting blade to cut.</p>

Item	Label	Description
2		<p>Cutting blades can break, causing severe injuries. Only use undamaged cutting blades. Do not use cracked, broken or twisted cutting blades.</p>
2		<p>Danger of poisoning. Do not inhale exhaust fumes. They contain toxic carbon monoxide that can lead to unconsciousness or death. In closed or partially closed rooms such as tunnels, drifts or deep trenches, ensure sufficient ventilation by, for example, providing a powerful exhaust air fan.</p>
3	<p style="text-align: center;">C14-86A e13*97/68SH3G3*2002/88*0650*00 WACKER NEUSON</p>	<p>EU emission information label</p>
3	<div style="border: 1px solid black; padding: 5px; margin-bottom: 10px;"> <p>EMISSION CONTROL INFORMATION ENGINE FAMILY: AEHXS.0866RA DISPLACEMENT: 85.8cc EMISSION COMPLIANCE PERIOD: 300Hours THIS ENGINE MEETS U.S.EPA EXH/EVP FOR MODEL YEAR 2010 REFER TO OWNER'S MANUAL FOR MAINTENANCE SPECIFICATIONS AND ADJUSTMENTS, FEB2010</p> <p style="text-align: right;"> WACKER NEUSON</p> </div> <p>This label is an example only and may vary from machine to machine.</p>	<p>EPA emission information label (for EPA machines). Emission Control (Exhaust & Evaporative) EPA 2010 and later. The emission control system for the engine is EM (Engine Modification) and for the fuel tank the control system is EVAP (Evaporative Emissions) or N (for Nylon tank). Product emission durability (Emission compliance period). The 300 hours emission durability compliance period is the time span selected by the manufacturer certifying the engine emissions output meets applicable emissions regulations, provided that approved maintenance procedures are followed as listed in the maintenance section of this manual.</p>

4 Safety and information labels

4.1 Safety and information icons

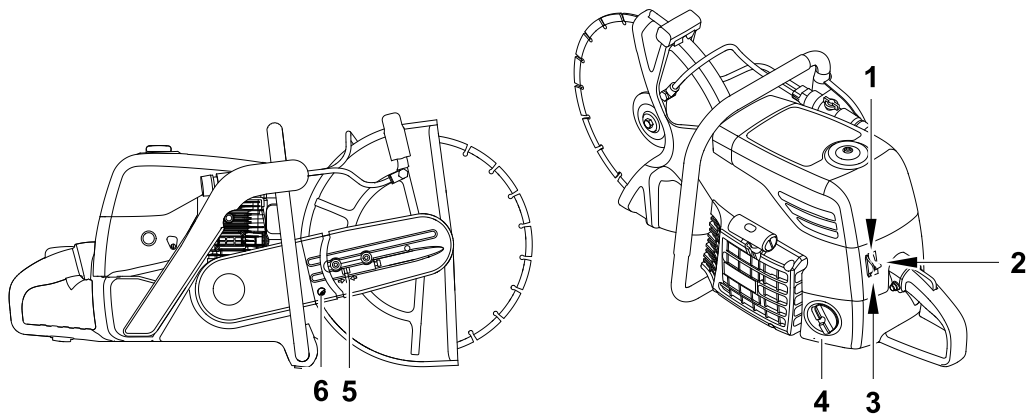

Item	Symbol	Description
1		Choke.
2		Start.
3		Stop.
4	MIX 50:1	The machine may only be operated with a fuel mixture consisting of unleaded gasoline and two-cycle engine oil. The mixture ratio is 50:1.
5		Mark for setting the V-belt tension.
6		Machine's direction of rotation. Mount the cutting blade such that its rotation direction is the same as that of the machine.

5 Scope of delivery

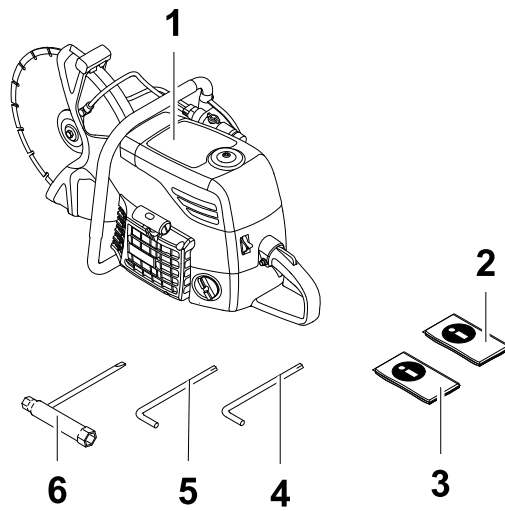

Item	Designation	Item	Designation
1	Machine	4	5 mm Allen wrench
2	Operator's manual	5	6 mm Allen wrench
3	Parts book	6	Combination wrench 13/19 mm

6 Structure and function

6.1 Application

Use the machine only as intended, see chapter *Safety, Proper use*.

6.2 Functionality

Principle

The machine is a gasoline cut-off saw.

It is driven by a two-cycle combustion engine.

The powertrain from the engine to the cutting blade is driven by a centrifugal clutch and V-belt.

The machine has an electronic ignition system that is maintenance-free.

The multi-stage air cleaner system consists of a cyclone, foam material prefilter and paper air cleaner cartridge.

7 Components and operator's controls

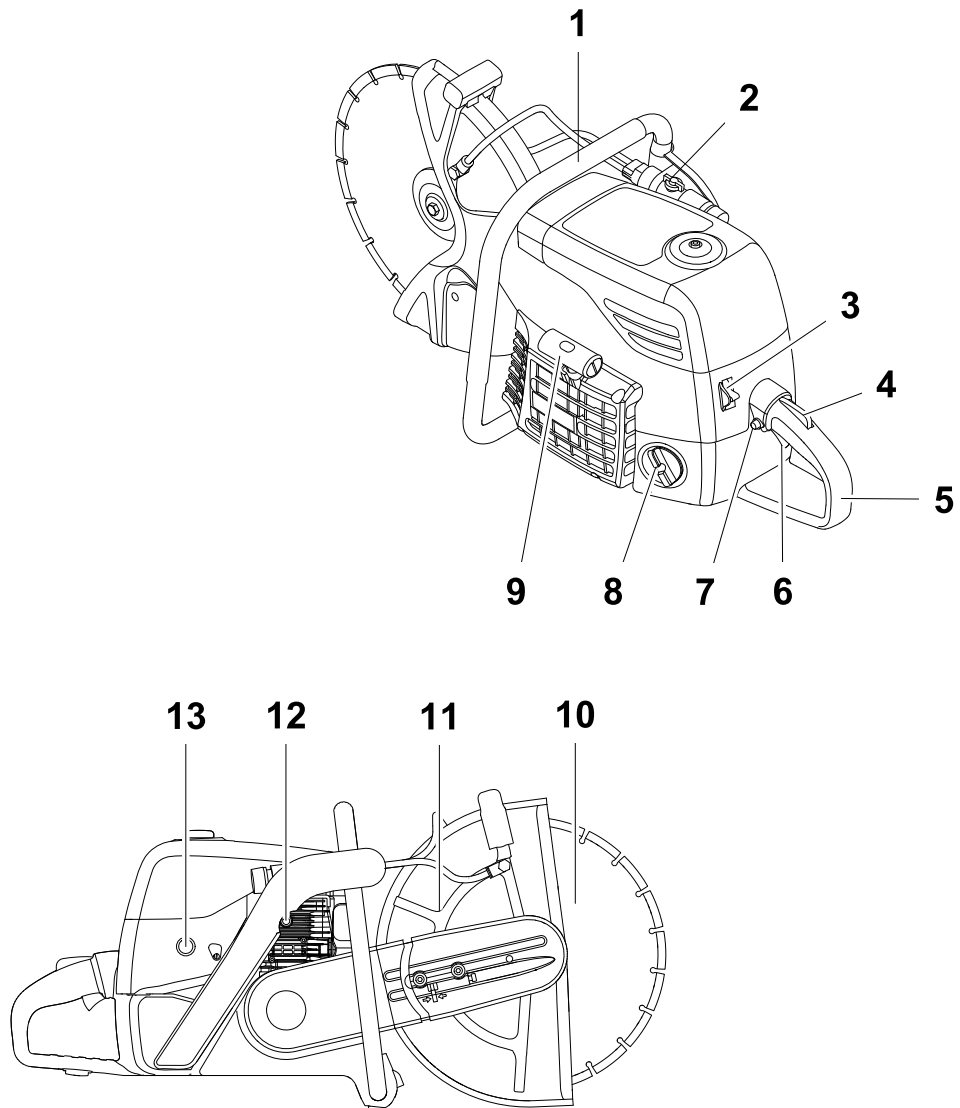

Item	Designation	Item	Designation
1	Front handle	8	Fuel tank
2	Water supply	9	Recoil starter
3	Multifunction switch	10	Cutting blade
4	Throttle lever lock	11	Protective hood
5	Rear handle	12	Decompression valve
6	Throttle lever	13	Fuel pump
7	Lock button		

Water supply

You can connect a water supply unit to the water supply connection.

The water supply performs the following functions:

- Cools the cutting blade evenly.
- Causes dust particles to stick together.

Multifunction switch

You can switch the machine on and off with the multifunction switch.

The multifunction switch has a choke setting for cold starts.

Throttle lever lock

Unintentional pressing of the throttle lever is prevented by the throttle lever lock.

You can only press the throttle lever if you are pressing the throttle lever lock at the same time.

If you release the throttle lever, the throttle lever lock also returns to its original position.

Throttle lever

The machine speed can be continuously varied using the throttle lever.

Lock button

The lock button can lock the throttle lever in the half-gas position.

Recoil starter

The recoil starter starts the engine.

Protective hood

The protective hood performs the following functions:

- Protects the operator from the rotating cutting blade.
- Diverts workpiece particles and sparks or chips from a damaged cutting blade away from the operator.

Set the protective hood for operation such that workpiece particles are diverted away from the operator.

Decompression valve

When starting the engine, the decompression valve allows some of the compressed air to escape from the cylinder. The lower compression in the cylinder reduces the drag on the starter rope.

When the engine is running, the decompression valve returns to its original position.

Fuel pump

The fuel pump is used to fill the fuel lines and the carburetor after the machine has not been used for a while. The integrated return pipe prevents too much fuel from entering the carburetor as a result of excessive pumping.



8 Transport



WARNING

Improper handling can result in injury or serious material damage.

- ▶ Read and follow all safety information of this operator's manual, see chapter *Safety*.
-



WARNING

Hazard of fire and explosions by fuel.

Any fuel that escapes can ignite and cause severe burns.

- ▶ Lift and move the machine in the upright position.
-

Transporting the machine

1. Switch off the engine.
2. Detach the cutting blade.
3. Lift the machine using the front handle.
4. Place the machine on or into a suitable means of transport.
5. Secure the machine against falling over and down or sliding.

9 Initial start up



WARNING

Improper handling can result in injury or serious material damage.

- ▶ Read and follow all safety information of this operator's manual, see chapter *Safety*.

9.1 Mounting the cutting attachment on the outside

By default the cutting attachment is mounted in the center of the machine.

The cutting attachment can be mounted on the outside to maneuver around obstacles that are very close to the cutting line (e.g. curbs or brick walls).

When the cutting attachment is in the external position, using the guide cart makes it even easier to see the cutting line.

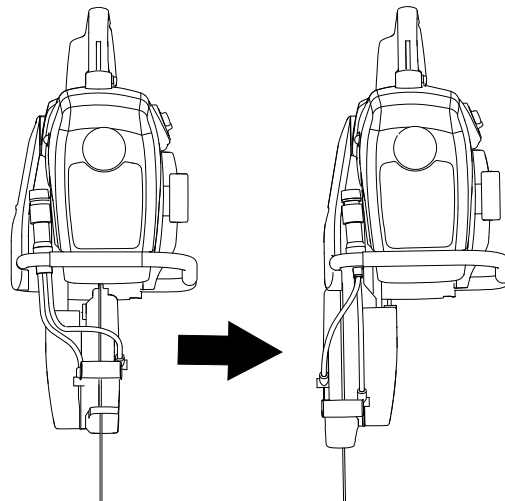

Performing preparations

1. Switch off the engine.
2. Let machine cool off.
3. Detach the cutting blade.

Note: You must detach the cutting blade because otherwise, after the conversion, the rotation direction of the cutting blade will no longer be the same as that of the machine.

Converting the protective hood

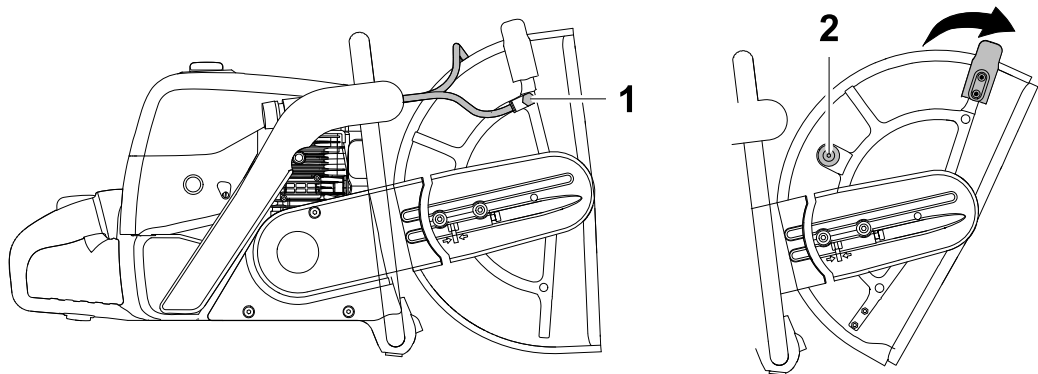

Item	Designation
1	Hose connection (2 pieces)
2	Vibration dampers

1. Unscrew both hose connections and remove them.
2. Rotate the protective hood clockwise as far as it will go.
3. Unscrew and remove the vibration dampers.

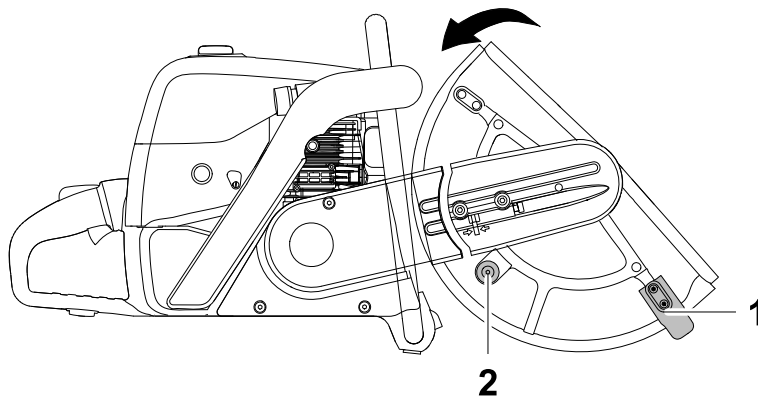

Item	Designation
1	Adjustment handle
2	Vibration dampers

4. Rotate the protective hood counter-clockwise until the mounting hole in the vibration damper is visible.
5. Position the vibration damper and tighten it.
6. Unscrew the adjustment handle on top and remove it.
7. Position the adjustment handle below and tighten it.

Slackening the V-belt

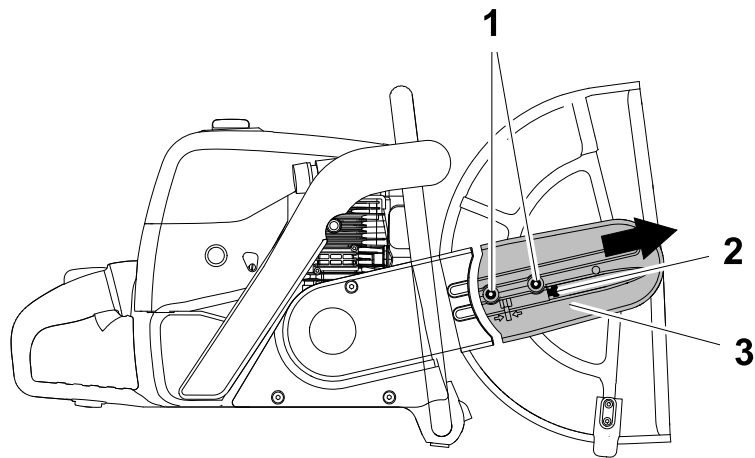

Item	Designation	Item	Designation
1	Screw (2 pieces)	3	Belt guard
2	Adjusting screw	4	

1. Loosen both belt guard screws by approximately one turn.
2. Rotate the adjusting screw counter-clockwise until the V-belt is slackened completely.
3. Unscrew the belt guard screws and remove them.
4. Remove the belt guard.

Mounting the cutting attachment on the outside

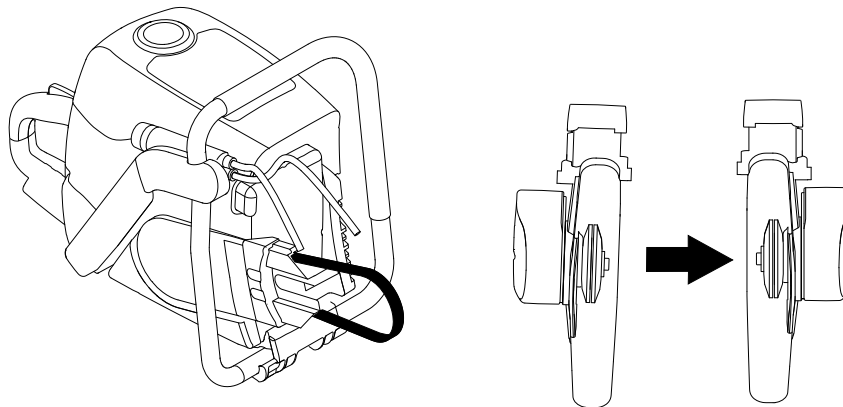

1. Remove the cutting attachment.
2. Clean the cutting attachment, V-belt pulley, belt guard and screws.
3. Rotate the cutting attachment 180° and place it in position.
4. Place the V-belt in position.

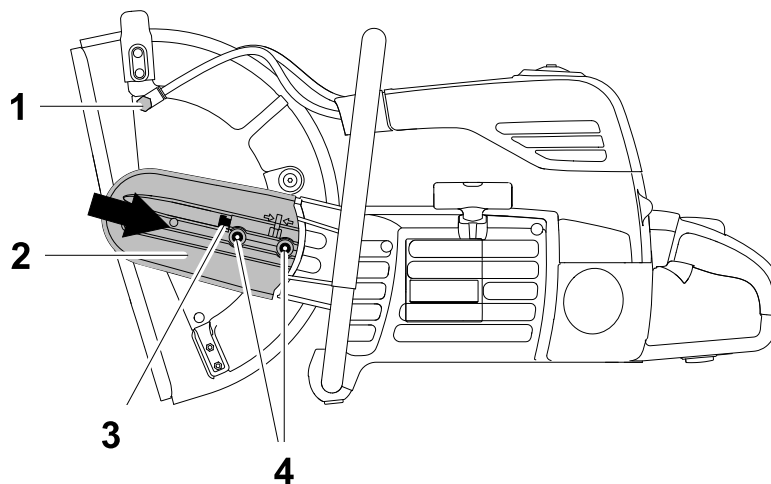

Item	Designation	Item	Designation
1	Hose connection (2 pieces)	3	Adjusting screw
2	Belt guard	4	Screw (2 pieces)

5. Place the belt guard in position and affix it with screws.
6. Rotate the adjusting screw clockwise until the square nut is located between the two marks.
7. Tighten the belt guard screws.
Torque 25 Nm.
8. Position the hose connections and tighten them.

9. Turn the thrust washer 2-3 times to make sure the tension is equal across the V-belt.
10. Check the V-belt tension again and re-tighten the V-belt if necessary.



10 Use and operation



WARNING

Improper handling can result in injury or serious material damage.

- ▶ Read and follow all safety information of this operator's manual, see chapter *Safety*.
-

10.1 Prior to starting the machine

10.1.1 Checks before startup

Checking the machine

Always check the following points before beginning work:

- Damage to the machine and to all components.
If the machine is damaged, do not start the machine. Have any damage or defects eliminated immediately.
- Damage to the cutting blade (cracks, sections broken off, deformation, off balance, etc.)
- Damage to the presurre disc (attrition, cleanness), see chapter *Maintenance*.
- Fuel level, see chapter *Maintenance*.
- V-belt tension, see chapter *Maintenance*.
- Tightness of the protective hood.

10.1.2 Changing the cutting blade

Performing preparations

1. Place the machine upright on a flat surface.
2. Set the multifunction switch to *Stop*.

Changing the cutting blade

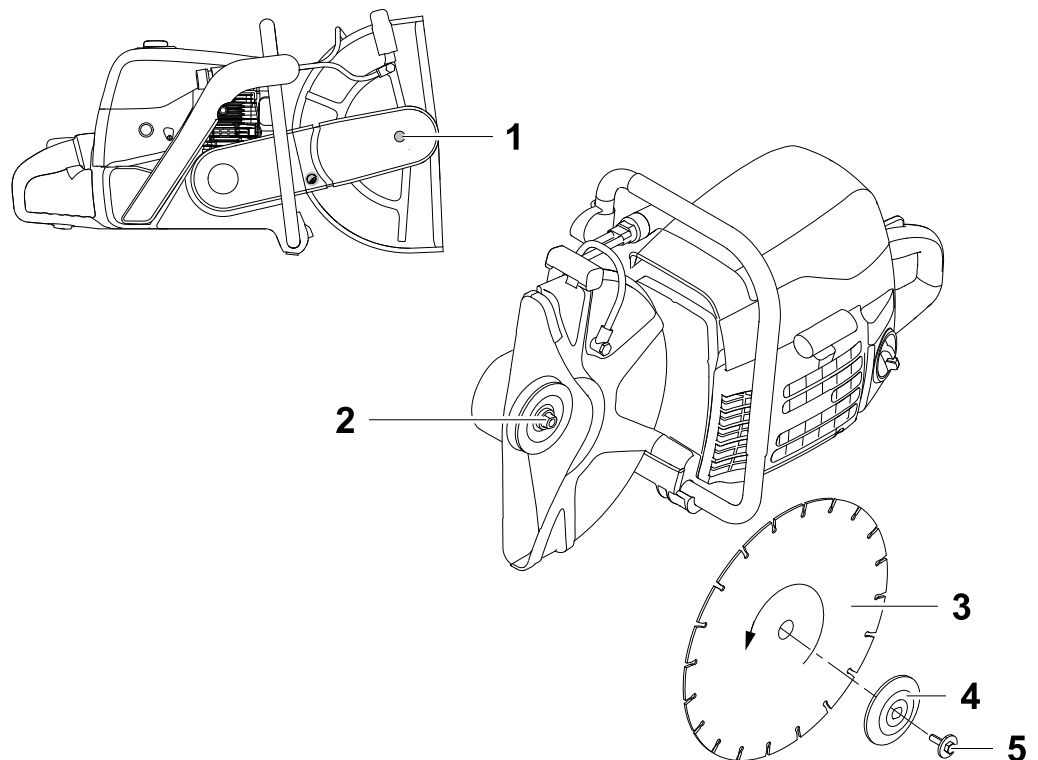

Item	Designation	Item	Designation
1	Bore	4	Thrust washer
2	Spindle	5	Screw
3	Cutting blade		

1. To block the shaft, put an Allen wrench into the bore.
Note: If necessary, rotate the spindle until the Allen wrench engages in the bore.
2. Unscrew and remove the screw together with the thrust washer.
3. Clean thrust washer and spindle of the machine.
4. Place the cutting blade onto the spindle in the correct rotation direction.
5. Place the screw together with the thrust washer in position and tighten.
Torque 25 Nm.
6. Remove the Allen wrench from the bore.
7. Test the new cutting blade for approx. 1 min at maximum speed (without cutting).

10.2 Starting up

10.2.1 Starting the engine

Performing preparations

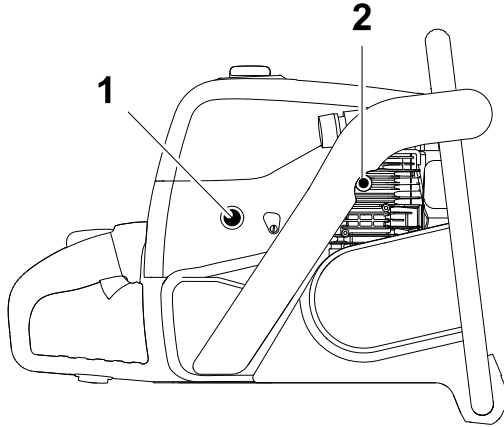

Item	Designation
1	Fuel pump
2	Decompression valve

1. Set down the machine such that the cutting blade can rotate freely.
2. Set the multifunction lever to the appropriate position.
Cold engine: Position "choke".
Warm engine: Position "I".
3. Press the fuel pump bellows repeatedly until the bellows is completely filled with fuel.
4. Actuate the decompression valve.
If you detect resistance when pressing, move the decompression valve back and forth a bit.
When the engine is running, the decompression valve returns to its original position.

Bringing the throttle lever into the start position

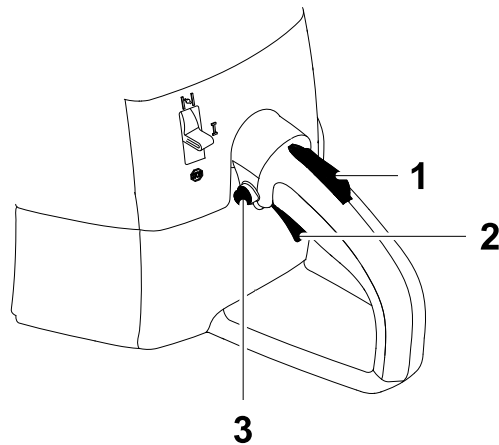

Item	Designation	Item	Designation
1	Throttle lever lock	3	Lock button
2	Throttle lever	4	

1. Press and hold the throttle lever lock and the throttle lever.
2. Press the lock button.
3. Release the throttle lever.
The throttle lever is locked in the half-gas position.
4. Release the lock button.

Starting the engine

NOTICE

Improper handling can damage the machine.

- ▶ Do not pull the starter rope as far as it can go.
 - ▶ Let starter rope slowly roll back in.
-



CAUTION

Incorrect handling during starting can result in minor injuries.

- ▶ Do not pull the starter rope until sufficient space is available and nobody is in the immediate vicinity.
-

Note: When starting the engine, move to a position at least 3 m from the fueling area.

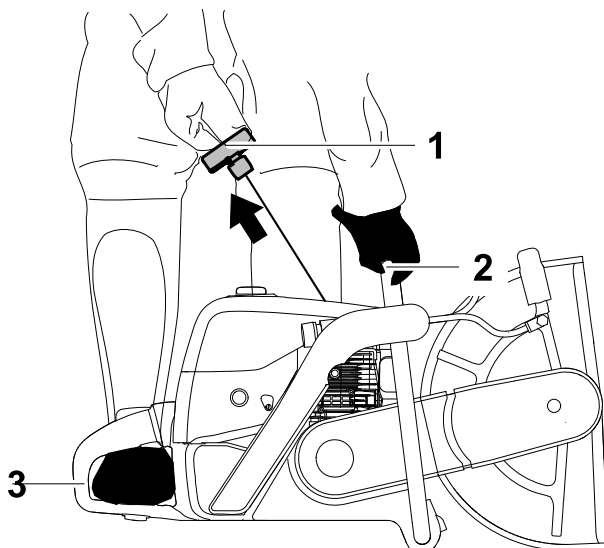

Item	Designation	Item	Designation
1	Starter rope	3	Rear handle
2	Front handle		

1. Grasp the front handle with one hand.
2. Place your foot in the rear handle to stabilize the machine.
3. Pull out the starter rope slowly until compression resistance can be felt and then let it slowly roll back in again.

4. Pull the starter rope with force, but not suddenly.
When you first hear the engine ignite, move the multifunction switch from the "Choke" position to the "I" position.
If necessary, actuate the decompression valve once again.
5. Pull the starter rope with force, but not suddenly (several times, if necessary) until the engine starts.
6. Let starter rope slowly roll back in.
7. Press the throttle lever to release the lock in the half-gas position.
8. Allow the engine to warm up.



10.3 Operating the machine

Note: When cutting, lightly pressing the cutting blade against the cutting material produces a very pleasant vibration response as well as a particularly narrow cut.

Holding and guiding the machine



WARNING

Injuries from insufficiently guided or uncontrolled machine.

- ▶ Always hold machine with both hands and stand firmly.
-

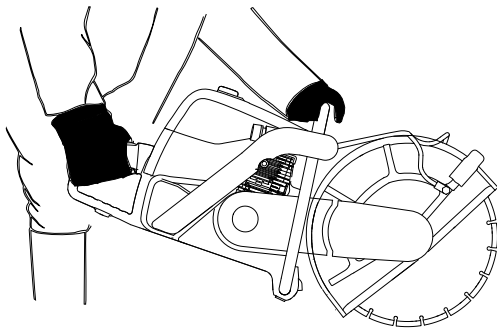

1. Stand in a fixed position.
2. Always hold the machine with both hands, using both handles.

Setting the protective cover

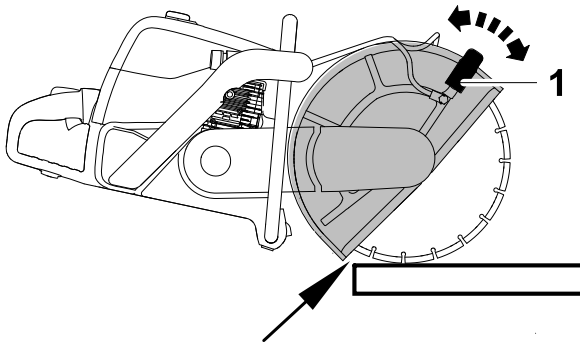

Item	Designation
1	Adjustment handle

- ▶ Use the adjustment handle to set the protective hood such that its lower section is almost in contact with the workpiece.

10.4 Decommissioning

Switching off the machine

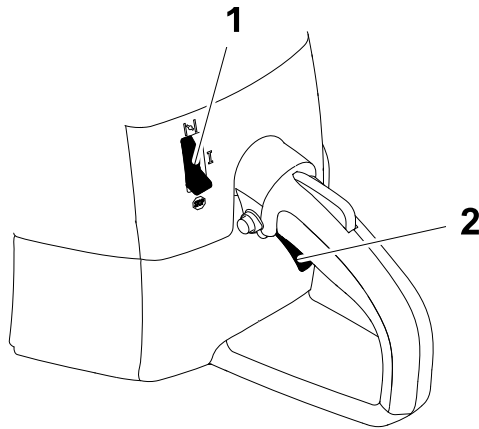

Item	Designation
1	Multifunction switch
2	Throttle lever

1. Release the throttle lever.
2. Set down the machine in such a way that it cannot tilt, fall or slip.
3. Set the multifunction switch to "Stop".
4. Detach the cutting blade and store in a dry place.

11 Maintenance



WARNING

Improper handling can result in injury or serious material damage.

- ▶ Read and follow all safety information of this operator's manual, see chapter *Safety*.
-



WARNING

Hazard of poisoning by exhaust fumes.

Exhaust fumes contain toxic carbon monoxide that can lead to unconsciousness or death.

- ▶ Carry out maintenance work only when the engine is off.
-

11.1 Maintaining the emission control system

Normal maintenance, replacement or repair of emission control devices and systems may be performed by any repair establishment or individual; however, warranty repairs must be performed by a dealer/service center authorized by Wacker Neuson.

The use of service parts that are not equivalent in performance and durability to authorized parts may impair the effectiveness of the emission control system and may have a bearing on the outcome of a warranty claim.

11.2 Maintenance schedule

Task	Daily before operation	Daily after operation	Every 50 hours or every six months	Every 90 hours or once a year
Check fuel system for: <ul style="list-style-type: none"> ■ Fuel tank fill level. ■ Leaks in fuel tank and fuel cap. 	■			
Check V-belt tension. Tighten V-belt as necessary.	■			
Visual inspection of all parts for damage.	■			
Check function of throttle lever, throttle lever lock and lock button.	■			
Check protective hood: <ul style="list-style-type: none"> ■ Damage. ■ Tightness. 	■			
Check cutting blade: <ul style="list-style-type: none"> ■ Damage. ■ Tightness. 	■			
Check thrust washers: <ul style="list-style-type: none"> ■ Damage. ■ Wear. 	■			
Clean the machine.		■		
Replace the fuel filter.			■	
Clean or replace spark plug.				■
Air cleaner: * <ul style="list-style-type: none"> ■ Clean air cleaner housing. ■ Change prefilter and air cleaner cartridge. 				■
Clean the muffler.				■
Replace fuel cap gasket.				■
Clean the spark arrestor (only for EPA machines in the USA and Canada).*				■

- * In case of loss in engine performance, shorten maintenance intervals.

Note: For EPA machines (in the USA and Canada), have the exhaust port of the machine cleaned by the service team of your Wacker Neuson contact every 90 h.

11.3 Maintenance work

Working in the workshop

Perform maintenance work in a workshop on a workbench. This has the following benefits:

- Protection of the machine of contamination on the construction site.
- A level and clean work surface makes work easier.
- There is a better overview over small parts and they are not lost as easily.

11.3.1 Cleaning the machine

- ▶ Wipe the housing with a damp and clean cloth.

11.3.2 Topping up with fuel



WARNING

Hazard of fire and explosions by fuel and fuel vapors.

- ▶ Do not smoke.
 - ▶ Do not refuel near open flames.
 - ▶ Turn off the engine before refueling and allow it to cool down.
-



CAUTION

Health hazard due to fuel.

- ▶ Refuel in a well-ventilated environment.
 - ▶ Do not inhale fuel vapors.
 - ▶ Avoid skin and eye contact with fuel.
-

Performing preparations

1. Switch off the engine.
2. Let the machine cool off.
3. Position the machine on its side such that the fuel cap points up.
4. Remove any dirt around the fuel cap.

Topping up with fuel

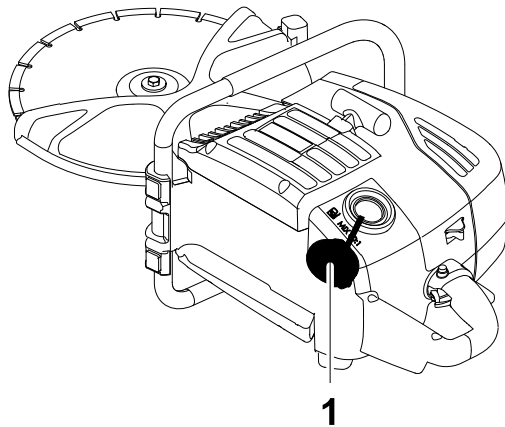

Item	Designation
1	Fuel cap

1. Slowly unscrew and remove the fuel cap.

Note: Slowly unscrew the fuel cap so that any overpressure can slowly escape.

2. Top up with fuel.

See chapter *Technical data* for the fuel specification.

See chapter *Technical data* for the fuel mixing table.

3. Position the fuel cap and tighten it.

11.3.3 Tightening the V-belt

Performing preparations

1. Switch off the engine.

Tightening the V-belt

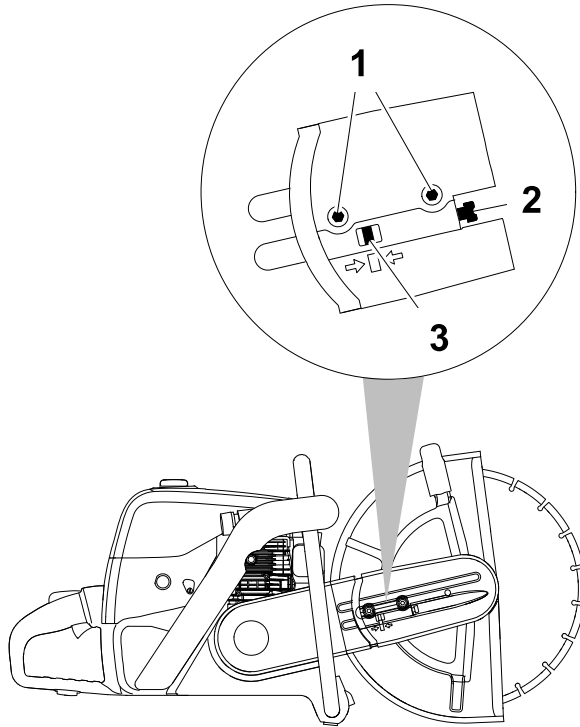

Item	Designation	Item	Designation
1	Screw (2 pieces)	3	Square nut
2	Adjusting screw		

1. Loosen both belt guard screws by approximately one turn.
2. Rotate the adjusting screw clockwise until the square nut is flush with the mark.
3. Tighten both belt guard screws.
Torque 25 Nm.

11.3.4 Checking the thrust washers

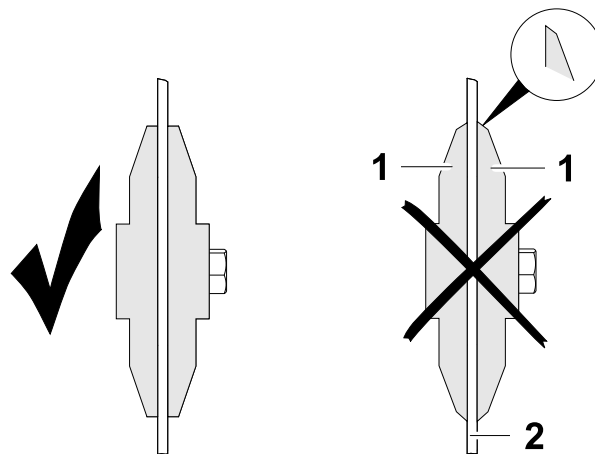

Item	Designation
1	Thrust washer (2 pieces)
2	Cutting blade

1. Check the thrust washers for wear and sharp edges.
In case of wear or damage, change the thrust washers.
2. Clean the thrust washers.

11.3.5 Cleaning/Changing the air cleaner

NOTICE

Operating the engine without air cleaner can cause rapid engine wear.

- ▶ Do not run the engine without an air cleaner or air cleaner cap.
-

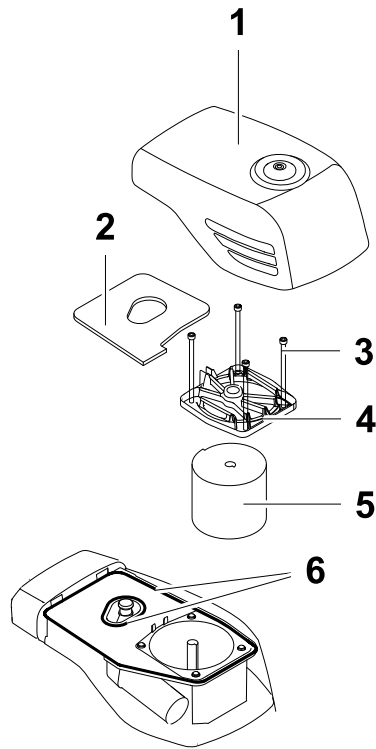

Item	Designation	Item	Designation
1	Air cleaner cap	4	Air cleaner cover
2	Prefilter	5	Air cleaner cartridge
3	Screw (4 pieces)	6	Seal (2 pieces)

Performing preparations

1. Switch off the engine.
2. Remove any dirt around the air cleaner cap.
3. Unscrew and remove the air cleaner cap.

Changing the prefilter

1. Remove the prefilter.
2. Clean the air cleaner cover and the entire air cleaner housing with a brush and a clean cloth.
Note: Use a vacuum cleaner to remove the dirt from the air cleaner housing.
3. Insert a new prefilter.

Changing the air cleaner cartridge

NOTICE

Dirt can fall into the engine combustion chamber and damage the engine.

- ▶ Before changing the air cleaner, clean the machine thoroughly.
-

1. Unscrew and remove the air cleaner cover.
2. Remove the air cleaner cartridge.
3. Insert new air cleaner cartridge.
4. Position the air cleaner cover and tighten it.
5. Position the air cleaner cap and tighten it.
Torque 5 Nm.
6. Check if the seals in the air cleaner housing are free of dirt and are correctly positioned. If necessary, clean the seals with a brush.

11.3.6 Checking/cleaning/replacing the spark plug



CAUTION

Touching a hot spark plug can cause burns.

- ▶ Only remove the spark plug when the engine has cooled down.
-

Performing preparations

1. Switch off the engine.
2. Let the machine cool off.

Removing the spark plug

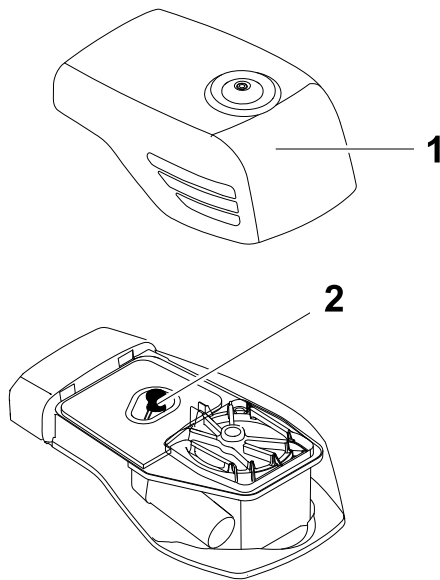

Item	Designation
1	Air cleaner cap
2	Spark plug cap

1. Unscrew and remove the air cleaner cap.
2. Clean the air cleaner housing and the area around the spark plug thoroughly.
3. Pull off the spark plug cap from the spark plug.
Note: Do not pull the spark plug cap off the spark plug by the ignition cable.
4. Loosen the spark plug with a combination wrench.
5. Unscrew the spark plug manually.

Checking/cleaning the spark plug

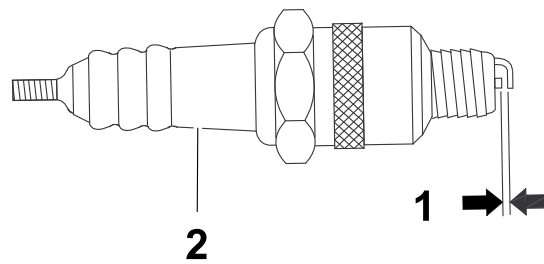

Item	Designation
1	Spark plug air gap
2	Isolator

1. Check the isolator – if damaged, replace the spark plug.
2. Clean the electrodes with a wire brush.
3. Measure the spark plug gap with a feeler gauge – if necessary, correct it by bending the lateral electrode.
See chapter *Technical data* for the spark plug gap.
4. Check the spark plug gasket – if damaged, replace the spark plug.

Installing the spark plug

NOTICE

A spark plug that is too loose or too tight can damage the engine.

- ▶ Tighten the spark plugs with the specified torque.

1. First screw in the spark plug manually then tighten it with a combination wrench.
2. Place the spark plug cap onto the spark plug.
3. Position the air cleaner cap and tighten it.
Torque 5 Nm.

11.3.7 Replacing the V-belt

Performing preparations

1. Switch off the engine.
2. Let the machine cool off.

Removing the covers

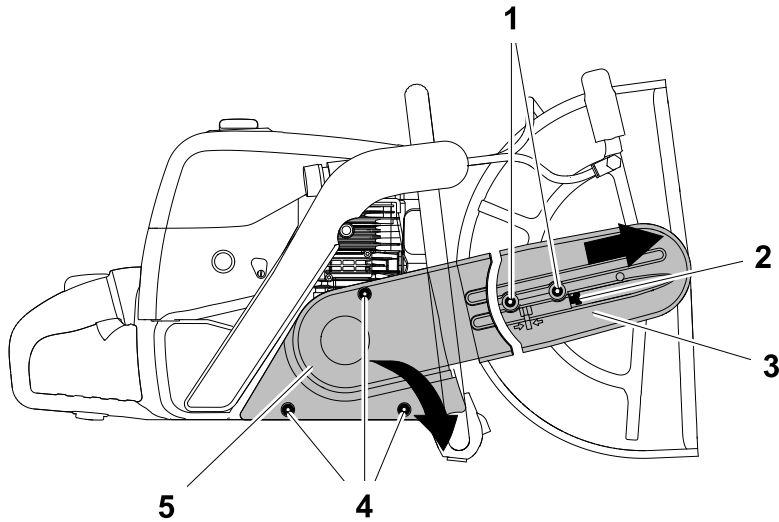

Item	Designation	Item	Designation
1	Screw (2 pieces)	4	Screw (3 pieces)
2	Adjusting screw	5	Clutch cover
3	Belt guard		

1. Rotate the adjusting screw counter-clockwise until the V-belt is slackened completely.
2. Unscrew the belt guard screws and remove them.
3. Remove the belt guard.
4. Loose the screws on the coupling cover.
5. Remove the clutch cover.

Replacing the V-belt

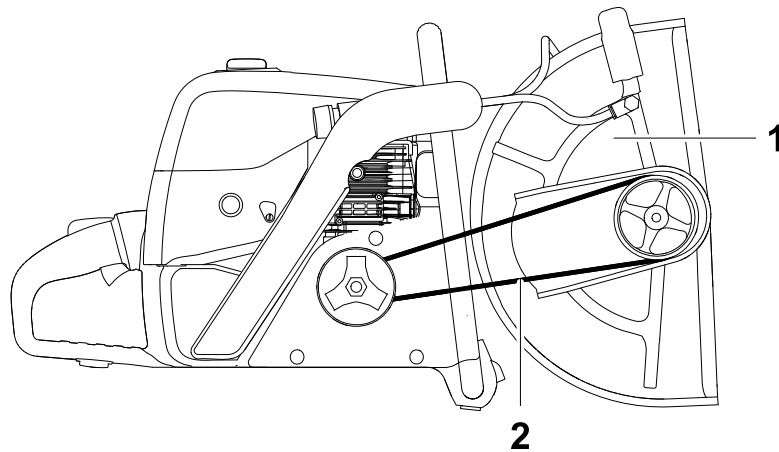

Item	Designation
1	Cutting attachment
2	V-belt

1. Remove the cutting attachment.
2. Remove the V-belt.
3. Place the new V-belt in position.
4. Place the cutting attachment in position and thread the V-belt in.

Attaching the covers

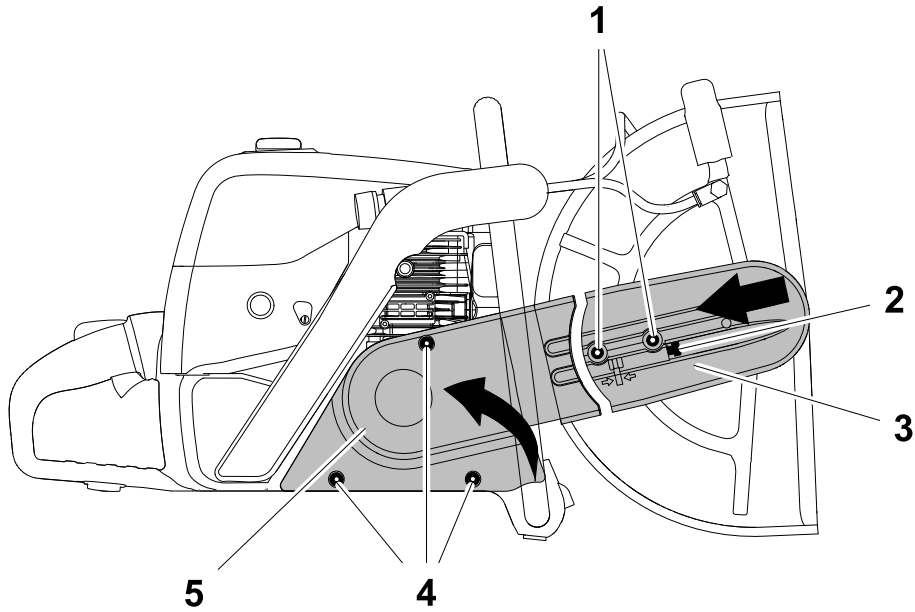

Item	Designation	Item	Designation
1	Screw (2 pieces)	4	Screw (3 pieces)
2	Adjusting screw	5	Clutch cover
3	Belt guard		

1. Place the clutch cover in position and tighten it with screws.
2. Place the belt guard in position and affix it with screws.
3. Rotate the adjusting screw clockwise until the square nut is flush with the mark.
4. Tighten the belt guard screws.
Torque 25 Nm.

11.3.8 Replacing the fuel filter

Note: The fuel filter is located in the tank. The fuel filter cannot be cleaned.

Performing preparations

1. Switch off the engine.
2. Let the machine cool off.
3. Empty the tank.

Replacing the fuel filter

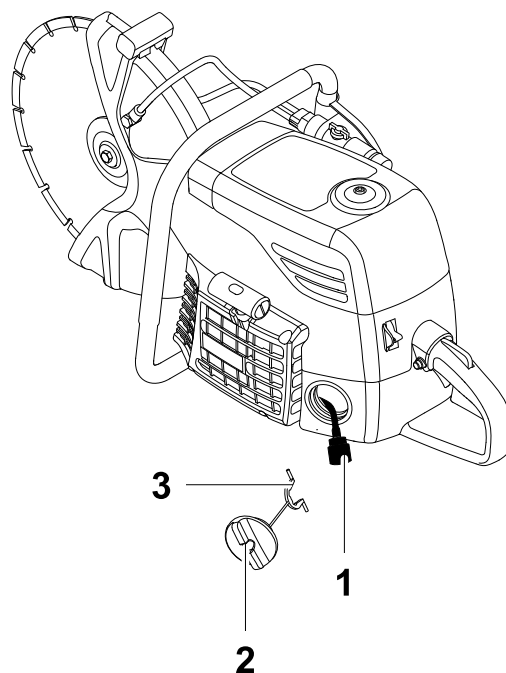

Item	Designation	Item	Designation
1	Fuel filter	3	Retainer
2	Fuel cap		

1. Unscrew the fuel cap.
2. Pull the fuel cap together with the retainer out of the fuel tank.
3. Pull the fuel filter out of the fuel tank with a wire hook.
4. Use a small screwdriver to loosen and remove the fuel filter.
5. Place a new fuel filter in position and press it in tightly.
6. Insert the fuel cap retainer into the fuel tank.
7. Position the fuel cap and tighten it.

11.3.9 Setting the idle speed

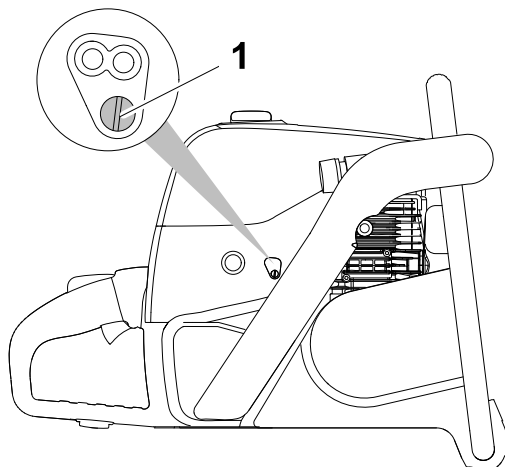

Item	Designation
1	Adjusting screw

1. Start the engine.
2. Allow the engine to warm up.
3. Set the idle speed with a screwdriver:
If the cutting blade rotates in idle, turn the adjusting screw for idle speed counter-clockwise until the cutting blade stops.
If the engine shuts off in idle, turn the adjusting screw a bit clockwise.

Note: If the cutting blade still rotates after setting the idle speed, have it repaired by your Wacker Neuson representative.

11.3.10 Cleaning the spark arrestor

Note: Only EPA machines (in the USA and Canada) have a spark arrestor.

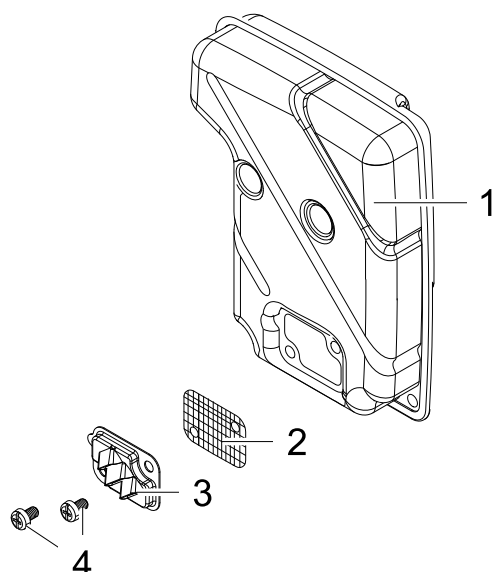

Item	Description	Item	Description
1	Muffler	3	Guide plate
2	Spark arrestor grid	4	Screw (2 pieces)

Cleaning the spark arrestor

1. Detach the cutting device, see chapter *Initial start up, mounting the cutting attachment on the outside*.
2. Unscrew and remove the guide plate.
3. Remove the spark arrestor grid.
4. Clean the spark arrestor grid using a wire brush.
5. Mount and screw the guide plate and spark arrestor grid into position.
Torque 2 Nm.
6. Install the cutting device, see chapter *Initial start up, mounting the cutting attachment on the outside*.

11.3.11 Cleaning the exhaust port

Note: For EPA machines (in the USA and Canada), have the exhaust port of the machine cleaned by the service team of your Wacker Neuson representative every 90 h.



CAUTION

Improper handling can severely damage the machine.

- ▶ Do not use hard or metallic tools for cleaning.
- ▶ Make sure that no combustion residue enters the cylinder.

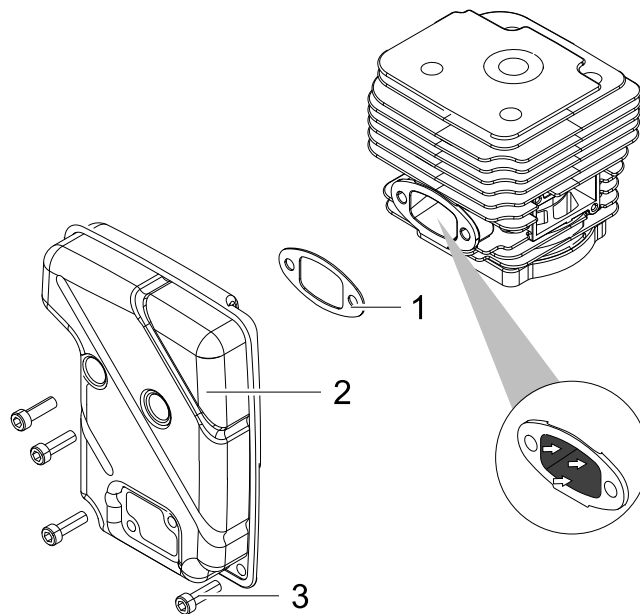

Item	Description	Item	Description
1	Seal	3	Screw (4 pieces)
2	Muffler		

1. Detach the cutting device, see chapter *Initial start up, mounting the cutting attachment on the outside*.
2. Remove the spark plug cap.
3. Unscrew and remove the muffler.
4. To stop the cylinder area from getting dirty, bring the piston to the top position.
5. Use a wooden tool (e.g. stick) to remove the combustion residue in the exhaust port.
6. Clean the seal face of the cylinder and muffler.

7. Screw the muffler (with new seal) to the cylinder.
Torque 18 Nm.
8. Install the cutting device, see chapter *Initial start up, mounting the cutting attachment on the outside*.



12 Troubleshooting

Potential faults, their causes and remedies can be found in the following table.

Notify your Wacker Neuson representative in case of malfunctions you cannot or may not remedy yourself.

Malfunction	Cause	Remedy
Engine does not start.	Multifunction switch is in the stop position.	Set multifunction switch to the "I" or the "Choke" position.
	Spark plug cap is defective.	Have the machine repaired. *
	Spark plug is defective.	Replace spark plug.
	Spark plug is loose.	Tighten spark plug.
	Spark plug gap is set incorrectly.	Set spark plug gap.
	Fuel filter is clogged.	Replace fuel filter.
Engine shuts off right after starting.	Idle speed is adjusted incorrectly.	Set idle speed.
	Fuel filter is clogged.	Replace fuel filter.
	Fuel tank is empty.	Top up with fuel.
Engine has low performance.	Air cleaner is dirty.	Replace air cleaner.
Cutting blade does not rotate.	V-belt is defective.	Replace V-belt.
	Clutch is defective.	Have the machine repaired. *
Cutting blade rotates in idle.	Idle speed is adjusted incorrectly.	Set idle speed.
Engine cannot be turned off.	Electrical connection of the multifunction switch is defective.	<ol style="list-style-type: none"> 1. Set multifunction switch to "Choke". The engine will switch off after a few seconds. 2. Have the machine repaired. *

* Have these tasks carried out by the service department of your Wacker Neuson representative.

13 Accessories

There is a wide range of accessories available for the machine.

For more information on the individual accessories, visit the following website:
www.wackerneuson.com.



14 Storage

If the machine will not be operated for a while, e.g. during the winter, do the following:

Performing preparations

1. Switch off the engine.
2. Detach the cutting blade and store in a dry place.
3. Let the machine cool off.

Emptying the fuel system

The gasoline in the fuel partially evaporates during long-term storage. The two-cycle oil in the fuel does not evaporate. After long-term storage the mixture ratio of gasoline to two-cycle oil is no longer correct. For this reason, the fuel system must be empty for long-term storage.

1. Remove any dirt around the fuel cap.
2. Slowly unscrew and remove the fuel cap.
3. Pump the fuel out into a suitable container or tank, e.g. with a suction pump.
4. Position the fuel cap and tighten it.
5. Start the engine and let it idle until the fuel in the carburetor is used up and the engine stops.

Storing the machine

1. Clean the machine.
2. Store the machine in a dry place.

15 Technical data

15.1 BTS 635s

Designation	Unit	BTS 635s	BTS 635s
Item no.		5100005408	5100005409
Soft Start		■	■
Length	mm (ft)	825 (2.7)	825 (2.7)
Width	mm (ft)	315 (1.0)	315 (1.0)
Height	mm (ft)	420 (1.4)	420 (1.4)
Weight (without cutting blade or accessories, tank empty)	kg (lb)	11,3 (24.9)	11,3 (24.9)
Min. cutting blade diameter	mm (in)	300 (12)	300 (12)
Max. cutting blade diameter	mm (in)	350 (14)	350 (14)
Spindle diameter	mm (in)	25,4 (1.0)	25,4 (1.0)
Max. width	mm (in)	4,5 (0.2)	4,5 (0.2)
Max. cutting depth	cm (in)	12,8 (5)	12,8 (5)
Peripheral speed with cutting blade 300 mm	m/s (ft/s)	67 (219.8)	67 (219.8)
Peripheral speed with cutting blade 350 mm	m/s (ft/s)	78 (255.9)	78 (255.9)
Max. spindle speed	rpm	4,240	4,240
Engine type		Gasoline engine	Gasoline engine
Combustion method		2-Cycle	2-Cycle
Cooling		Air cooling	Air cooling
Cylinder		1	1
Engine displacement	cm ³ (cm ³)	86 (5.3)	86 (5.3)
Fuel type		Regular gasoline, lead-free 91 ROZ (87 R+M) bf	Regular gasoline, lead-free 91 ROZ (87 R+M) bf

15 Technical data

Designation	Unit	BTS 635s	BTS 635s
Fuel consumption	l/h (gal/h)	2,3 (0.6)	2,3 (0.6)
Fuel mixture ratio		50:1	50:1
Tank capacity	l (gal)	1,1 (0.3)	1,1 (0.3)
Oil specification		ISO L-EGD	ISO L-EGD
Rated output	kW	4,3	4,3
Rated speed	rpm	9,300	9,300
Speed run-dry	rpm	2,800	2,800
Type of spark plug		NGK BPMR-7A	NGK BPMR-7A
Spark plug air gap	mm (in)	0,6 (0.24)	0,6 (0.24)
Speed (max. power)	rpm	10,000	10,000
Sound pressure level L_{PA} at operator's station	dB(A)	104	104
Standard		DIN EN ISO 19432	DIN EN ISO 19432
Measured sound power level L_{WA}	dB(A)	115	115
Guaranteed sound power level L_{WA}	dB(A)	117	117
Standard		DIN EN ISO 19432	DIN EN ISO 19432
Total vibration value of the acceleration a_{hv} at the front handle	m/s^2 (ft/s^2)	4,6 (15.1)	4,6 (15.1)
Total vibration value of the acceleration a_{hv} at the rear handle	m/s^2 (ft/s^2)	3,5 (11.5)	3,5 (11.5)
Standard		DIN EN ISO 19432	DIN EN ISO 19432
Uncertainty of measurement of the vibration total value of the acceleration a_{hv}	m/s^2 (ft/s^2)	1,5 (4.9)	1,5 (4.9)

15.2 Fuel mixture table

Note: Only use fuel in a mixture ratio of 1:50.

Gasoline volume in liters (qt)	Oil volume in liters (qt)
1 (1.06)	0,02 (0.02)
5 (5.28)	0,1 (0.11)
10 (10.57)	0,2 (0.21)
15 (15.85)	0,3 (0.32)
20 (21.13)	0,4 (0.42)
25 (26.42)	0,5 (0.53)

16 Emission Control Systems Information and Warranty

The Emission Control Warranty and associated information is valid only for the U.S.A., its territories, and Canada.

16.1 Emission Control System Background Information

Introduction

Wacker Neuson spark-ignited engines/equipment must conform with applicable Environmental Protection Agency (EPA) emissions regulations. There are two types of emissions that fall under these regulations: 1) exhaust, and 2) evaporative. These regulations require that manufacturers warrant the emission control systems for defects in materials and workmanship.

Furthermore, EPA regulations require all manufacturers to furnish written instructions describing how to operate and maintain the engines/equipment including the emission control systems. This information is provided with all Wacker Neuson engines/equipment at the time of purchase.

Exhaust Emissions

The combustion process produces carbon monoxide, oxides of nitrogen, and hydrocarbons. Control of hydrocarbons and oxides of nitrogen is very important because, under certain conditions, they react to form photochemical smog when subjected to sunlight. Carbon monoxide does not react in the same way, but it is toxic.

Wacker Neuson utilizes lean carburetor settings and other systems to reduce the emissions of carbon monoxide, oxides of nitrogen, and hydrocarbons.

Evaporative Emissions

Evaporative emissions are fuel emissions and generally include emissions that result from permeation of fuel through the fuel-system materials or from ventilation of the fuel system.

Wacker Neuson utilizes low-permeation fuel lines and fuel tanks where applicable to reduce evaporative emissions.

Problems that may affect Emissions

If any of the following symptoms arise, have the engine/equipment inspected and repaired by a Wacker Neuson dealer/service center.

- Hard starting or stalling after starting
- Rough idling
- Misfiring or backfiring under load
- Afterburning (backfiring)
- Presence of black exhaust smoke during operation
- High fuel consumption

Tampering and Altering

Tampering with or altering the emission control system may increase emissions beyond the legal limit. If evidence of tampering is found, Wacker Neuson may deny a warranty claim. Among those acts that constitute tampering are:

- Removing or altering of any part of the air intake, fuel, or exhaust systems.
- Altering or defeating the speed-adjusting mechanism causing the engine to operate outside its design parameters.

16.2 Limited Defect Warranty for Wacker Neuson Emission Control Systems

The Emission Control Warranty is valid only for the U.S.A., its territories, and Canada.

Wacker Neuson Sales Americas, LLC, N92 W15000 Anthony Avenue, Menomonee Falls, WI 53051, (hereinafter "Wacker Neuson") warrants to the initial retail purchaser, and each subsequent owner, that this engine/equipment, including all parts of its emission control systems, have been designed, built, and equipped to conform at the time of initial sale to all applicable emission regulations of the U.S. Environmental Protection Agency (EPA), and that the engine/equipment is free of defects in materials and workmanship which would cause this engine/equipment to fail to conform to EPA regulations during its warranty period.

Wacker Neuson is also liable for damages to other engine/equipment components caused by a failure of any warranted parts during the warranty period.

Limited Defect Warranty Period for Wacker Neuson Emission Control Systems

The warranty period for this engine/equipment begins on the date of sale to the initial purchaser and continues for a minimum of two (2) years. For the warranty terms for your specific engine/equipment, visit wackerneuson.com.

Any implied warranties are limited to the duration of this written warranty.

What is covered

Wacker Neuson recommends the use of genuine Wacker Neuson parts, or the equivalent, whenever maintenance is performed. The use of replacement parts not equivalent to the original parts may impair the effectiveness of the engine/equipment emission controls systems. If such a replacement part is used in the repair or maintenance of the engine/equipment, assure yourself that such part is warranted by its manufacturer to be equivalent to the parts offered by Wacker Neuson in performance and durability. Furthermore, if such a replacement part is used in the repair or maintenance of the engine/equipment, and an authorized Wacker Neuson dealer/service center determines it is defective or causes a fail-

ure of a warranted part, the claim for repair of the engine/equipment may be denied. If the part in question is not related to the reason the engine/equipment requires repair, the claim will not be denied.

For the components listed in the following table, an authorized Wacker Neuson dealer/service center will, at no cost to you, make the necessary diagnosis, repair, or replacement necessary to ensure that the engine/equipment complies with the applicable EPA regulations. All defective parts replaced under this warranty become property of Wacker Neuson.

Exhaust Emissions

Systems Covered	Components
Fuel metering system	Carburetor and internal parts
	Air/fuel ratio feedback system (if applicable)
	Cold start enrichment system (if applicable)
	Regulator assembly (if applicable)
Exhaust system	Catalytic muffler (if applicable)
	Exhaust manifold (if applicable)
Air induction system	Air filter housing
	Air filter element*
	Intake manifold (if applicable)
Ignition system	Flywheel magneto
	Ignition module
	Electronic controls (if applicable)
	Spark advance/retard system (if applicable)
	Spark plug cap
	Spark plug*
Miscellaneous parts associated with the exhaust emission control system	Tubing
	Fittings
	Seals
	Gaskets
	Clamps
* Indicates expendable maintenance items. Warranted only to first scheduled replacement point.	

Evaporative Emissions

Systems Covered	Components
Evaporative control system	Fuel tank (if applicable)
	Fuel tank cap (if applicable)
	Fuel line (if applicable)
	Fuel line fittings (if applicable)
	Clamps (if applicable)
	Carbon canister (if applicable)
	Purge port connector (if applicable)
Miscellaneous parts associated with the evaporative emission control system	Clamps
	Gaskets
	Mounting brackets

What is not covered

- Failures other than those resulting from defects in material or workmanship.
- Any systems or parts which are affected or damaged by owner abuse, tampering, neglect, improper maintenance, misuse, improper fueling, improper storage, accident and/or collision; the incorporation of, or any use of, add-on or modified parts, or unsuitable attachments, or the alteration of any part.
- Replacement of expendable maintenance items made in connection with required maintenance services after the item's first scheduled replacement as listed in the maintenance section of the engine/equipment operator's manual, such as spark plugs and filters.
- Incidental or consequential damages such as loss of time or the use of the engine/equipment, or any commercial loss due to the failure of the engine/equipment.
- Diagnosis and inspection charges that do not result in warranty-eligible service being performed.
- Any non-authorized replacement part, or malfunction of authorized parts due to use of non-authorized parts.

Owner's Warranty Responsibility

The engine/equipment owner is responsible for the performance of the required maintenance listed in the Wacker Neuson engine/equipment operator's manual. Wacker Neuson recommends that all receipts covering maintenance on the engine/equipment be retained, but Wacker Neuson cannot deny warranty coverage solely for the lack of receipts or for the failure to ensure the performance of all scheduled maintenance.

Normal maintenance, replacement, or repair of emission control devices and systems may be performed by any repair establishment or individual; however, warranty repairs must be performed by an authorized Wacker Neuson dealer/service center.

The engine/equipment must be presented to an authorized Wacker Neuson dealer/service center as soon as a problem exists. Contact Wacker Neuson Product Support Department (1-800-770-0957) or visit wackerneuson.com to find a dealer/service center in your area, or to answer questions regarding warranty rights and responsibilities.

How to Make a Claim

In the event that any emission-related part is found to be defective during the warranty period, you shall notify Wacker Neuson Product Support Department (1-800-770-0957, or technical.support@wackerneuson.com, or wackerneuson.com), and you will be advised of the appropriate dealer/service center where warranty repair can be performed. All repairs qualifying under this limited warranty must be performed by an authorized Wacker Neuson dealer/service center.

You must take your Wacker Neuson engine/equipment along with proof of original purchase date, at your expense, to the authorized Wacker Neuson dealer/service center during their normal business hours.

For owners located more than 100 miles from an authorized dealer/service center (excluding the states with high-altitude areas as identified in 40 CFR Part 1068, Appendix III), Wacker Neuson will pay for pre-approved shipping costs to and from an authorized Wacker Neuson dealer/service center.

Claims for repair or adjustment found to be caused solely by defects in material or workmanship will not be denied because the engine/equipment was not properly maintained and used.

The warranty repairs should be completed in a reasonable amount of time, not to exceed 30 days.



EC Declaration of Conformity

Manufacturer

Wacker Neuson Produktion GmbH & Co. KG, Wackerstraße 6, D-85084 Reichertshofen

This declaration of conformity is issued under the sole responsibility of the manufacturer.

Product

Product	BTS635s
Product type	Gasoline cut-off saw
Function of product	Cutting materials
Item number	5100005408

Guidelines and standards

We hereby declare that this product complies with the relevant provisions and requirements of the following guidelines and standards:

2006/42/EC (2014-02), 2014/30/EU (2014-02), EN ISO 19432 (2012-07), EN ISO 14982 (2009-02)

Person responsible for technical documents

Robert Rätthsel,

Wacker Neuson Produktion GmbH & Co. KG, Wackerstraße 6, D-85084 Reichertshofen

Reichertshofen, 24/07/2017

Helmut Bauer
Managing Director

